

2022 IACC Conference

- Complete Streets program update
- Importance of small city pavement maintenance
- Cross-section design

Chris Workman, PE- Engineering Manager
Andrew Beagle, PE- Region Engineer





Today's Topics

- Complete Streets program update
- Pavement maintenance
- Cross-section design





Transportation Improvement Board (TIB)

The TIB funds high priority transportation projects in communities throughout the state to enhance the movement of people, goods and services.

34

years in operation

4,792

projects funded

\$3.2B

in TIB Funding

308

active projects

\$205.0M

current obligation



Transportation Improvement Board (TIB)

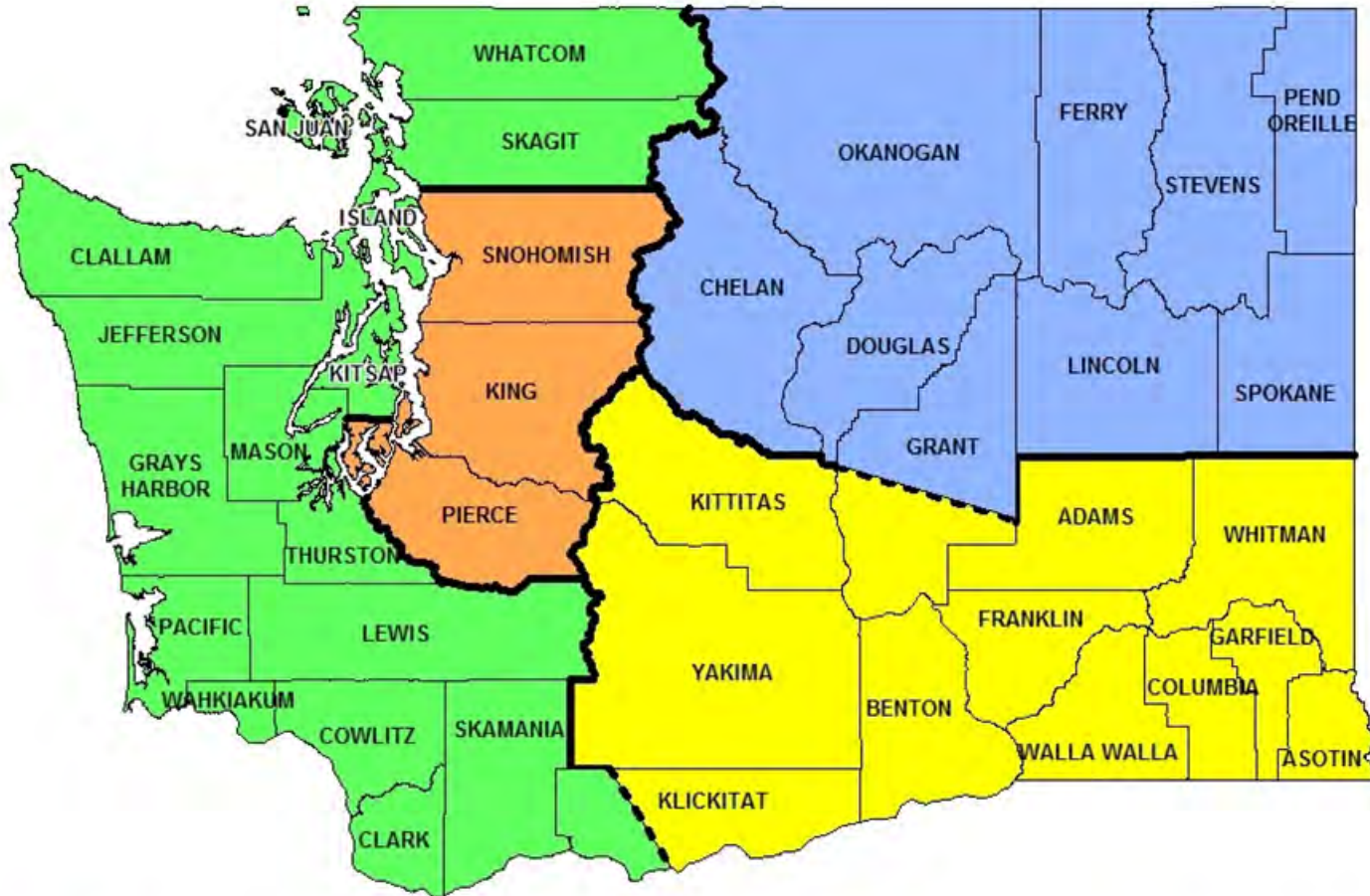

Greg Armstrong
GregA@tib.wa.gov
360.480.7428



Chris Langhoff
ChrisL@tib.wa.gov
360.508.5528



Andrew Beagle
AndrewB@tib.wa.gov
360.586.1151



Jonathan Heusman
JonathanH@tib.wa.gov
360.259.8428



Complete Streets Program Update



RCW 47.04.320

...provide safe access to all users, including bicyclists, pedestrians, motorists, and public transportation users, with goals of:

- Promoting healthy communities
- Improving safety
- Protecting the environment and reducing congestion
- Preserving community character





What is a Complete Street?





What is a Complete Street?

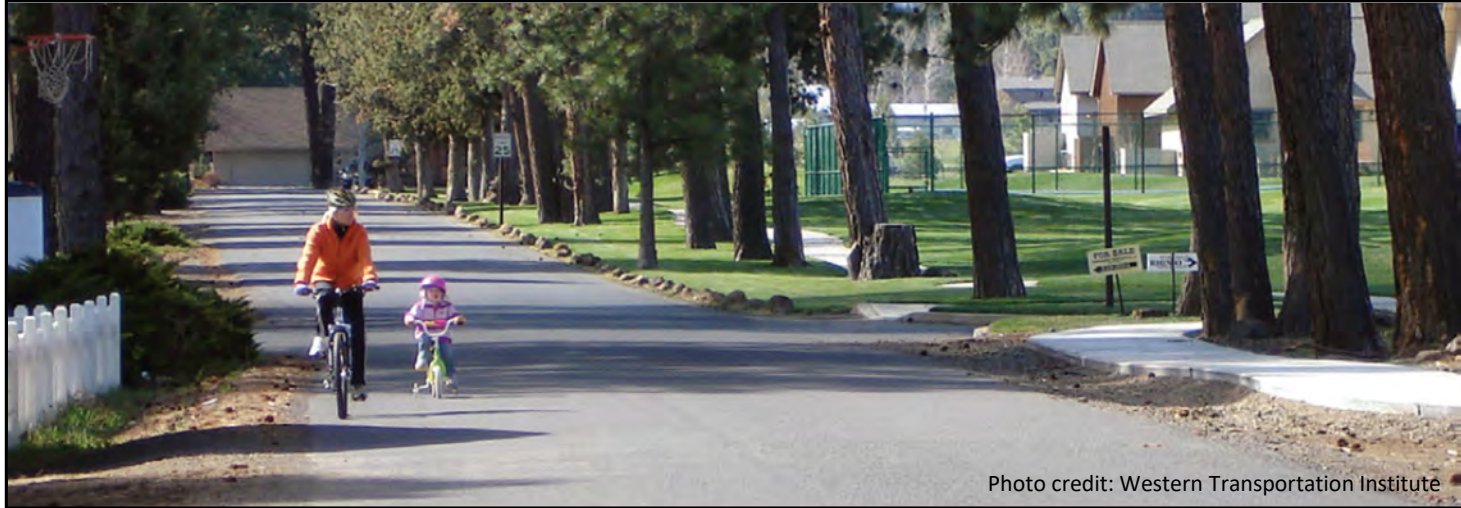

Photo credit: Western Transportation Institute



Photo credit: Western Transportation Institute



Common Situations

- Sidewalk / Ramps
- Crossing (RRFB's)



- Widen shoulder
- Separated path





Complete Streets



Introduction

The *Small Town and Rural Multimodal Networks* guide is a design resource and **idea book to help small towns and rural communities** support safe, accessible, comfortable, and active travel for people of all ages and abilities.

In many small towns and rural communities, active transportation is even more common than it is in urban areas. However, infrastructure to support active transportation is often limited or absent. Many small and rural communities are located on State and county roadways that were built

The guide is intended to:

- Provide a bridge between existing guidance and pedestrian and rural practice.
- Encourage innovative and appealing solutions for bicycling and walking in small towns and rural areas.
- Provide examples of best practices.



Complete Streets Examples





The New Complete Streets Program





Complete Streets Adopted Ordinances

Complete Streets Adoption for Washington Cities and Counties 2006-2022

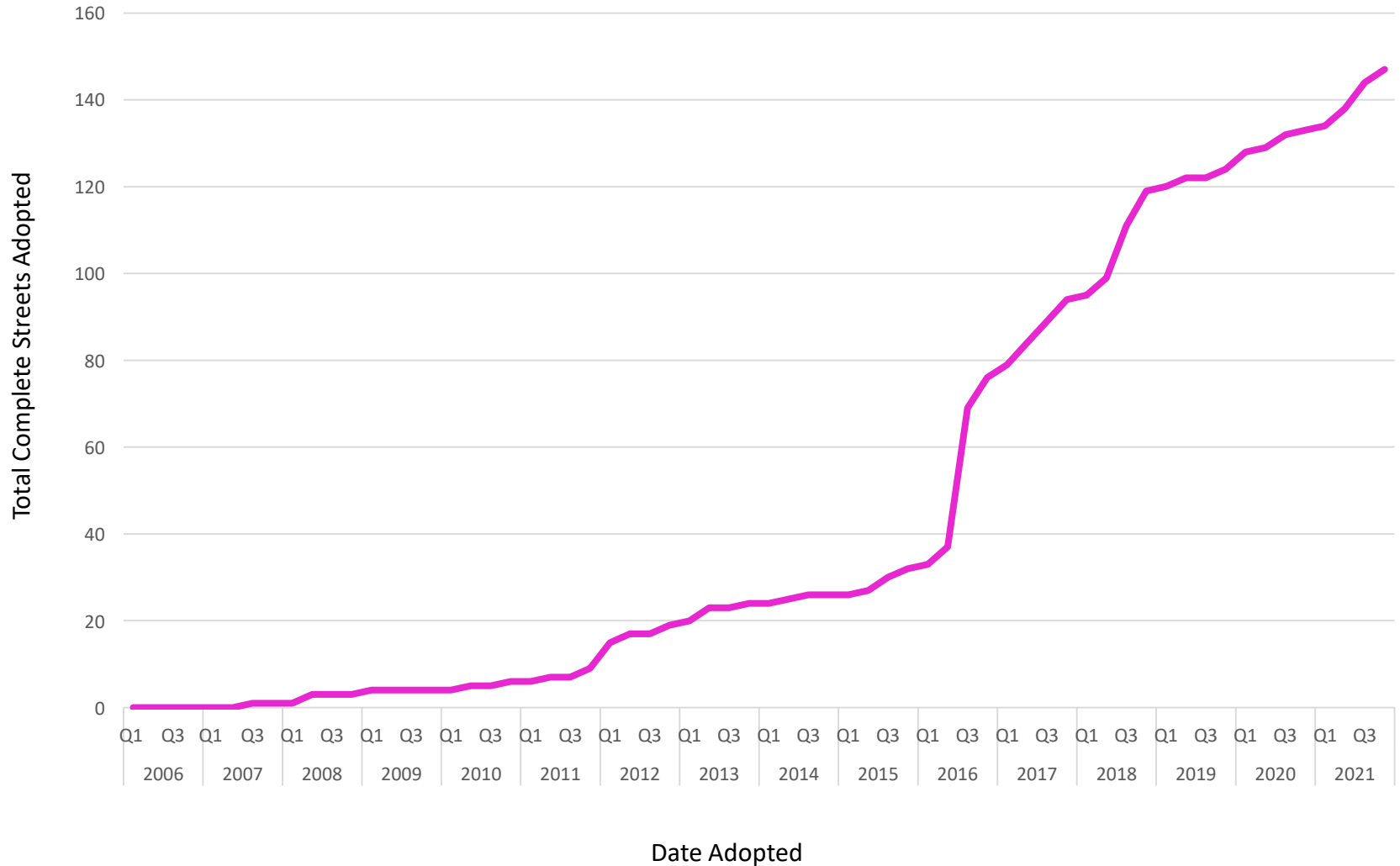



Successful Policies

1. Set a vision.
2. Include all users and all modes.
3. Apply to all phases of all applicable projects.
4. Specify and limit exceptions, with high-level approval required.
5. Emphasize connectivity.
6. Understood by all agencies to cover all roads.
7. Use best and latest design standards.
8. Complement the community's context.
9. Set performance measures.
10. Include implementation steps.





Walla Walla





Walla Walla





Walla Walla





Questions?



Small City Preservation



Cashmere (PCR average= 71.2)

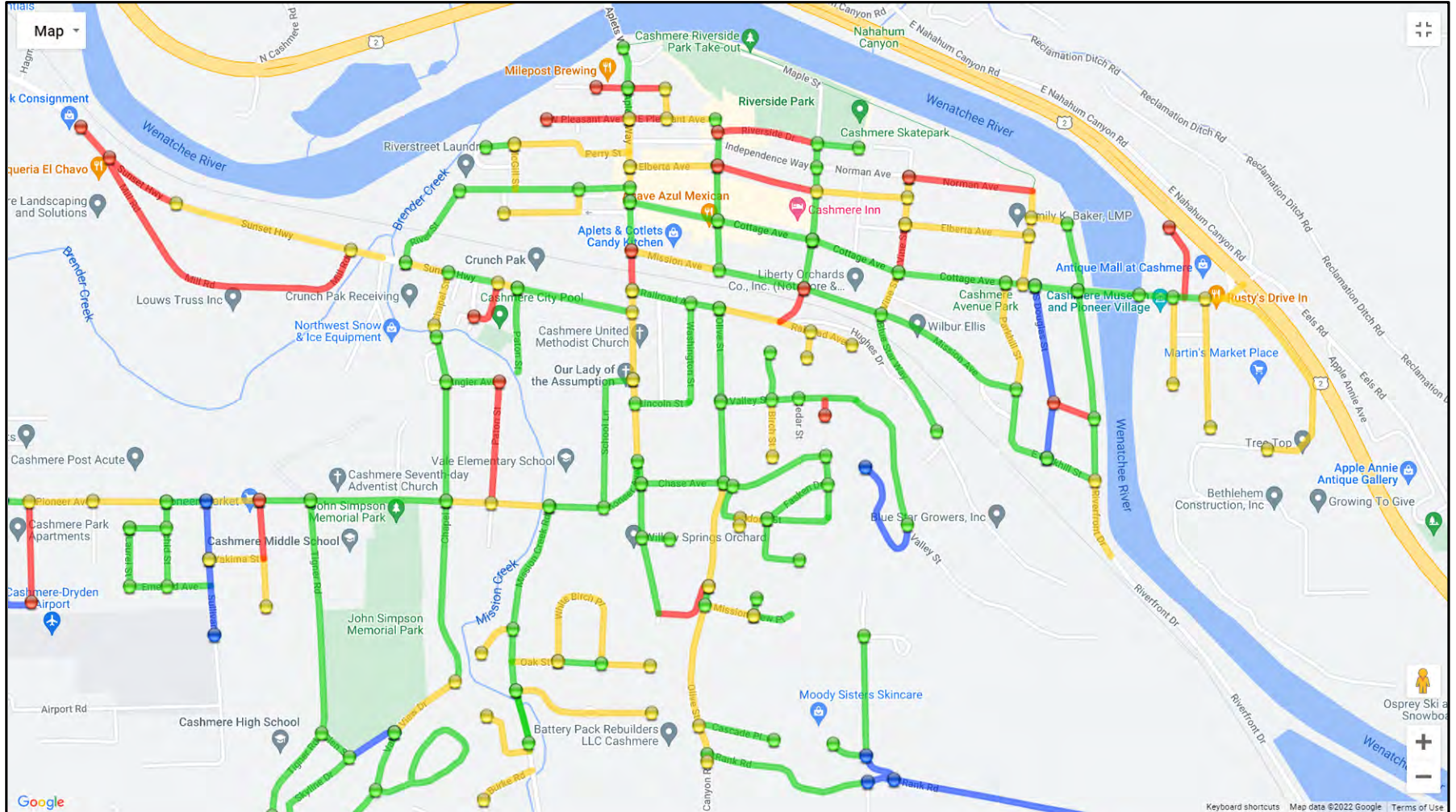



2008 Small City Pavement Ratings

173 small cities

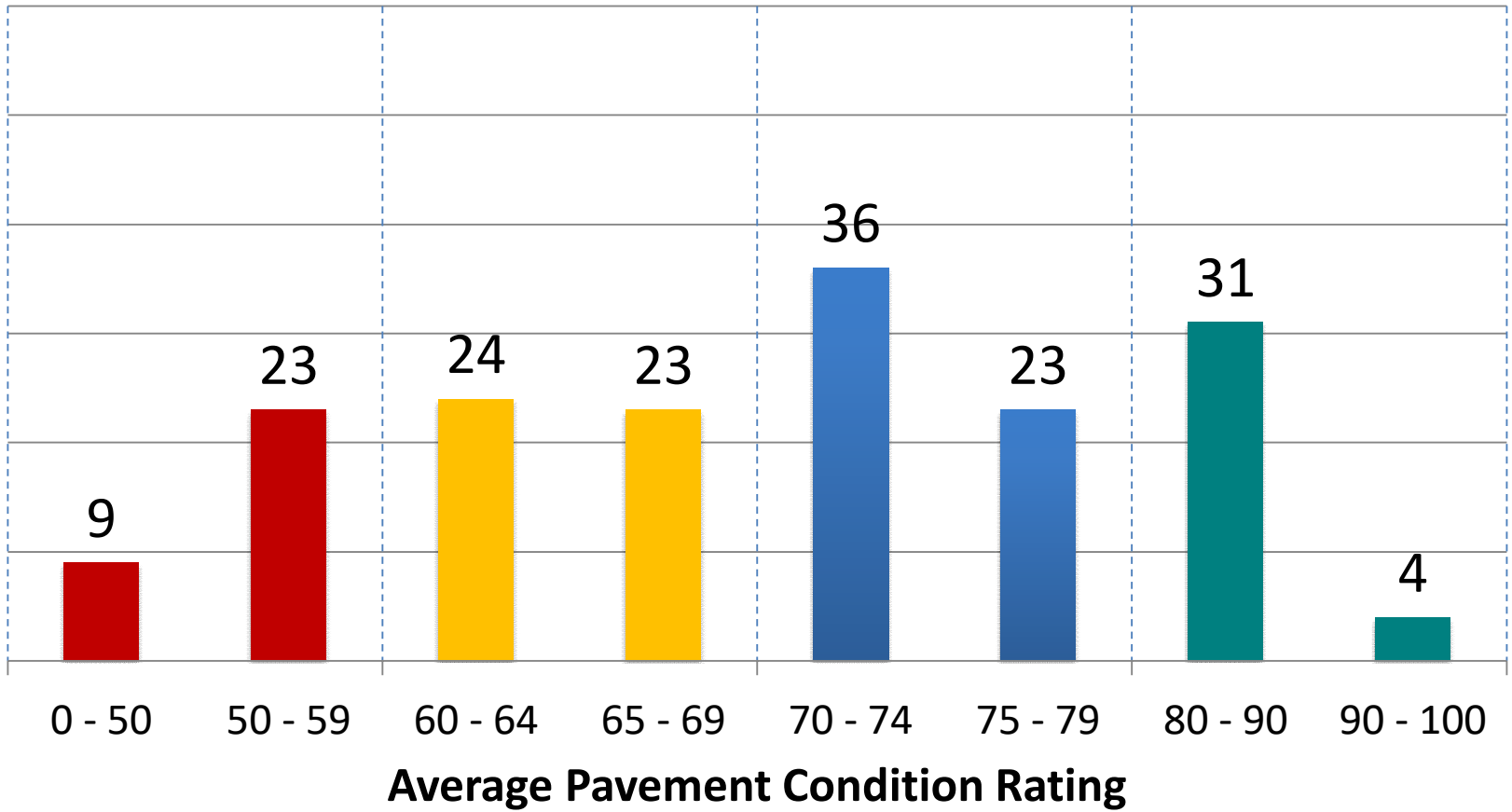



2016 Small City Pavement Ratings

164 small cities

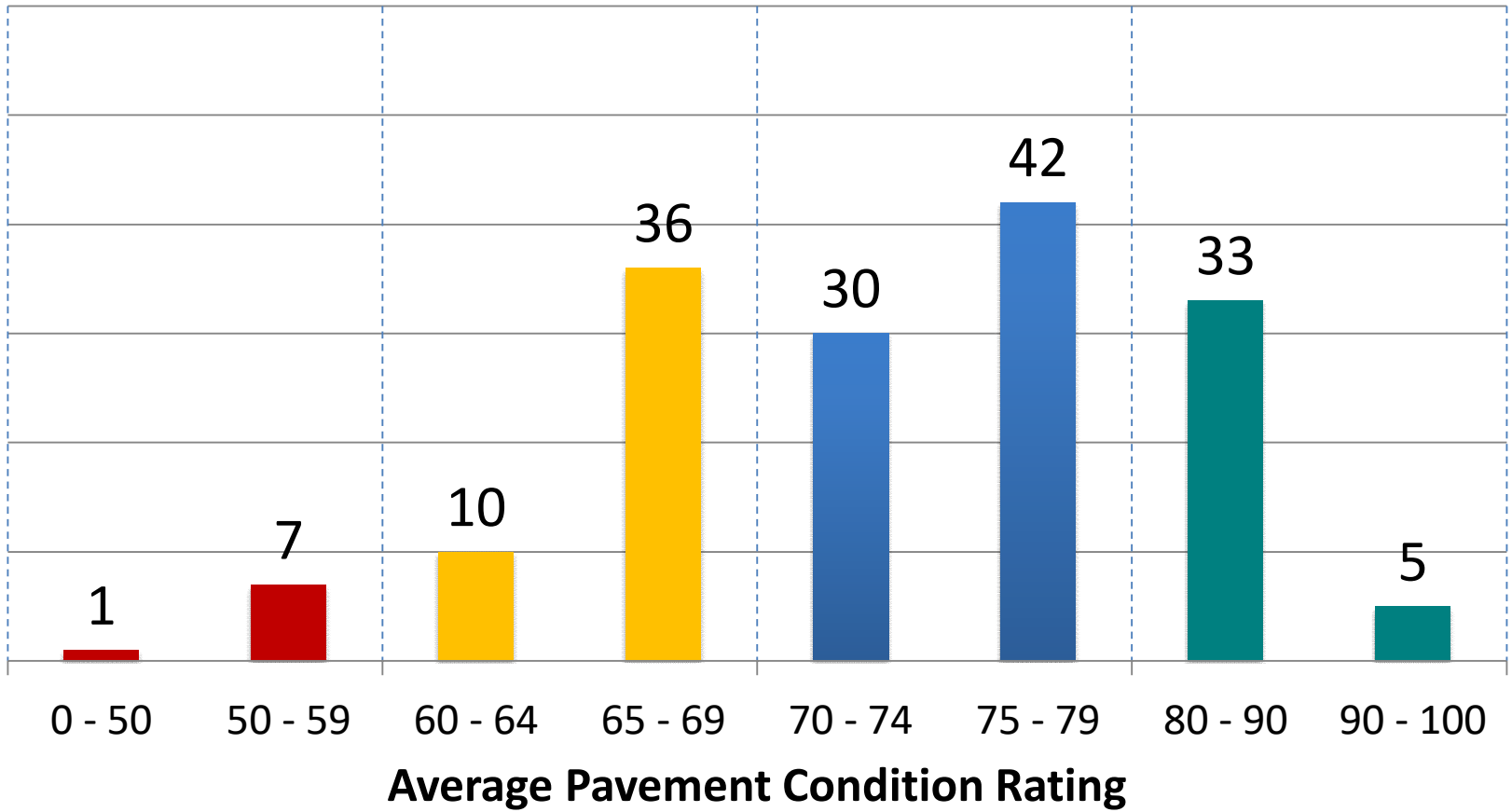



2020 Small City Pavement Ratings

161 small cities

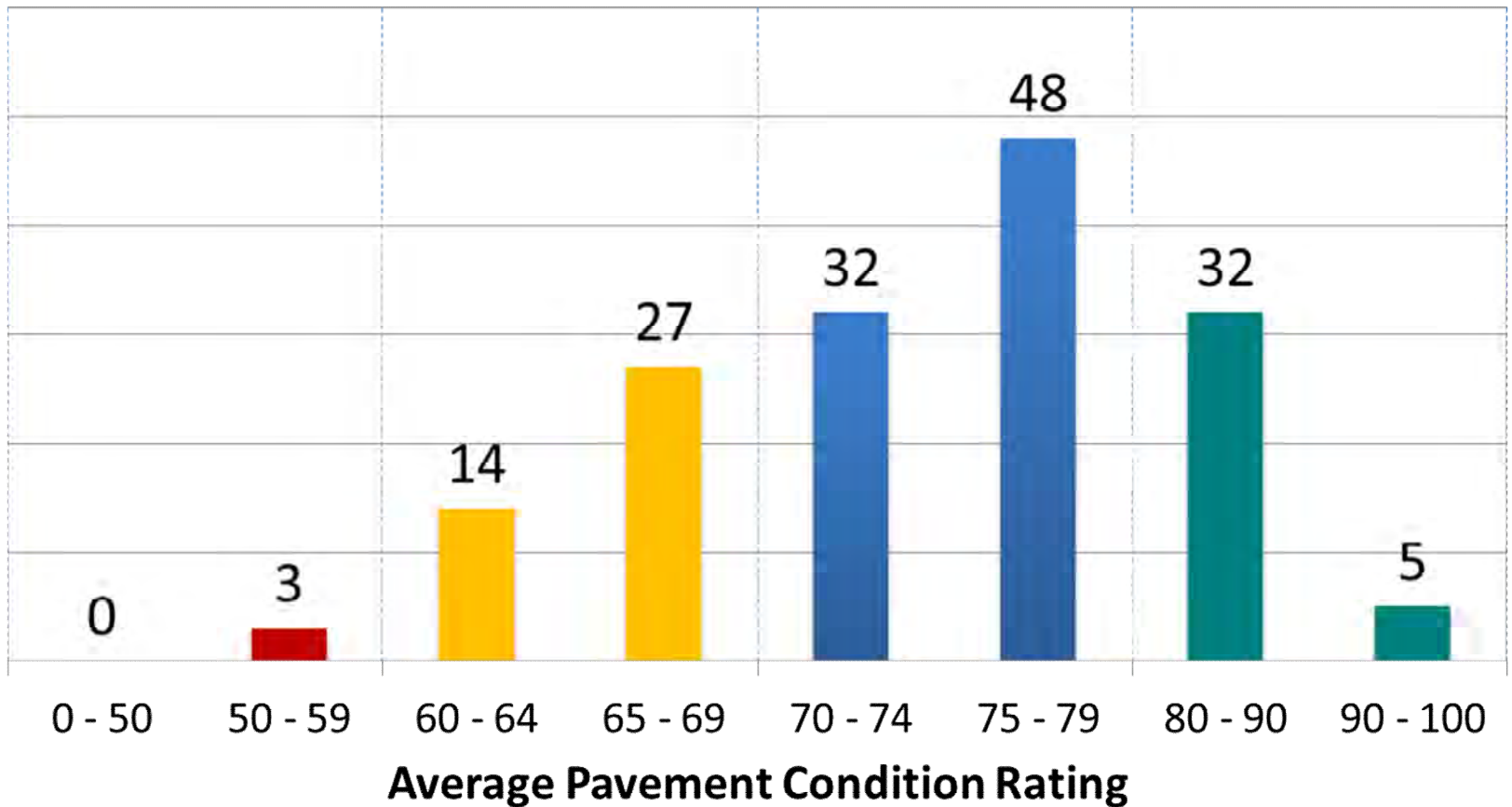



2022 Small City Pavement Ratings

161 small cities

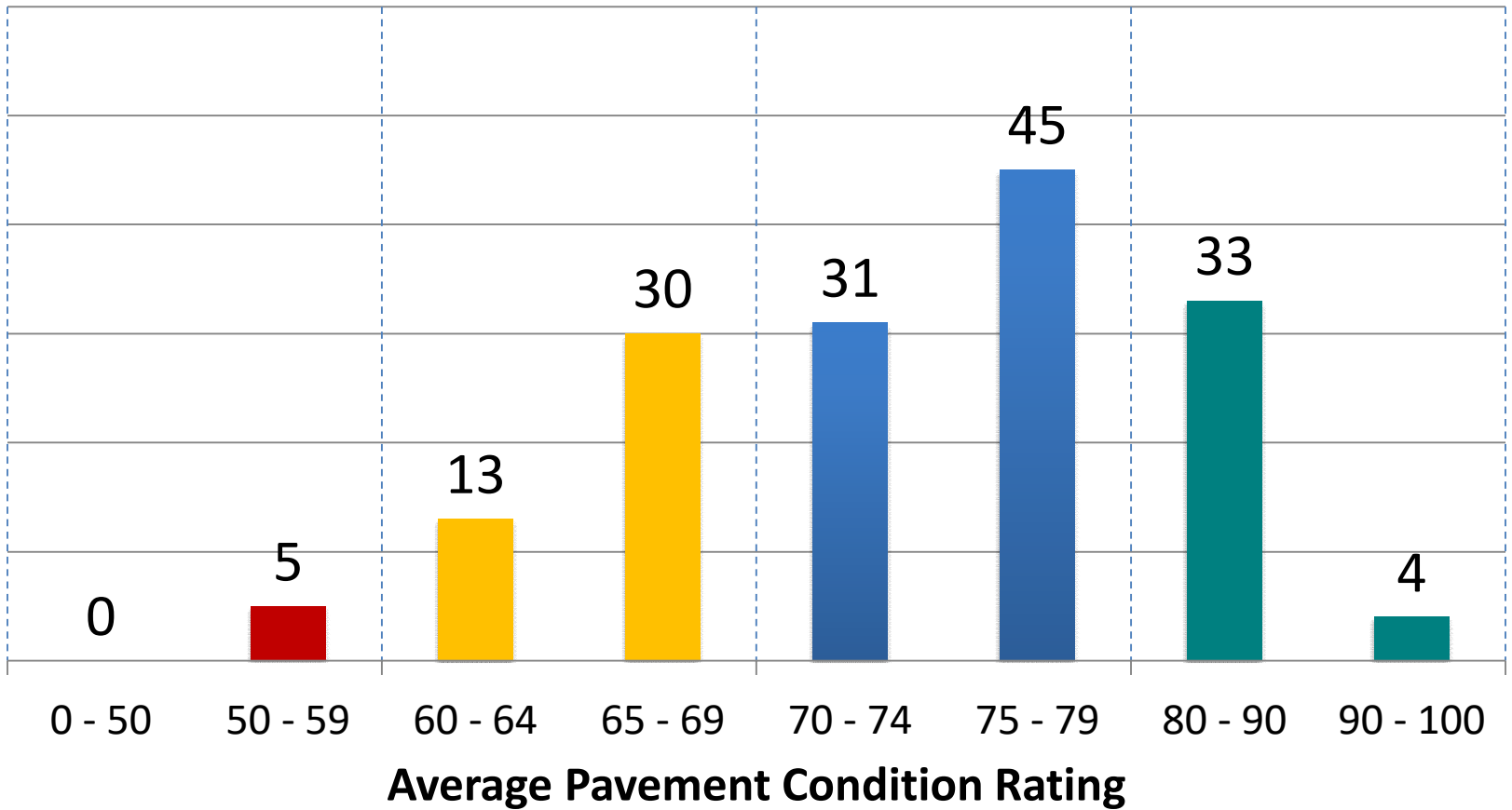



2022 Small City Pavement Ratings

161 small cities

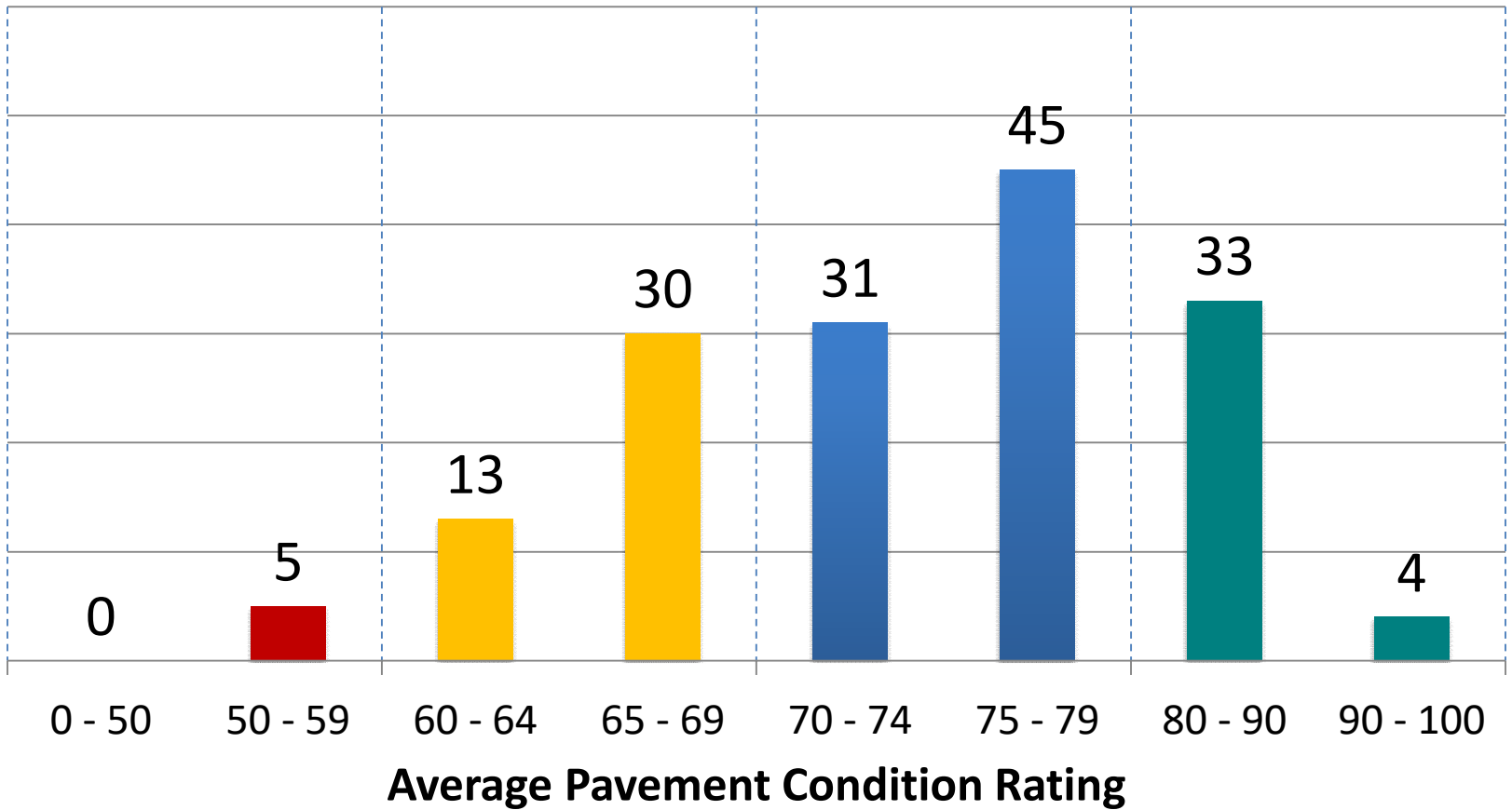



PCR 0-59= Red

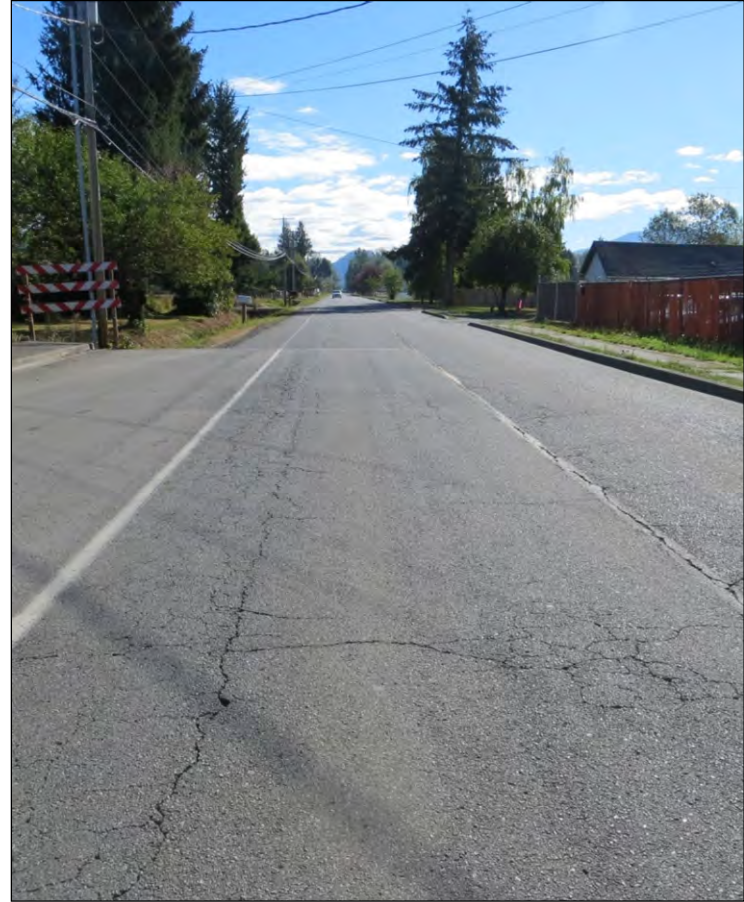



PCR 60-69= Yellow





PCR 70-79= Blue





PCR 80-100= Teal





TIB Preservation Programs

Small City Preservation (SCPP)

- Maintenance
- Seal coat
- Overlay



Questions?



Cross Section Design



What is a Cross Section?

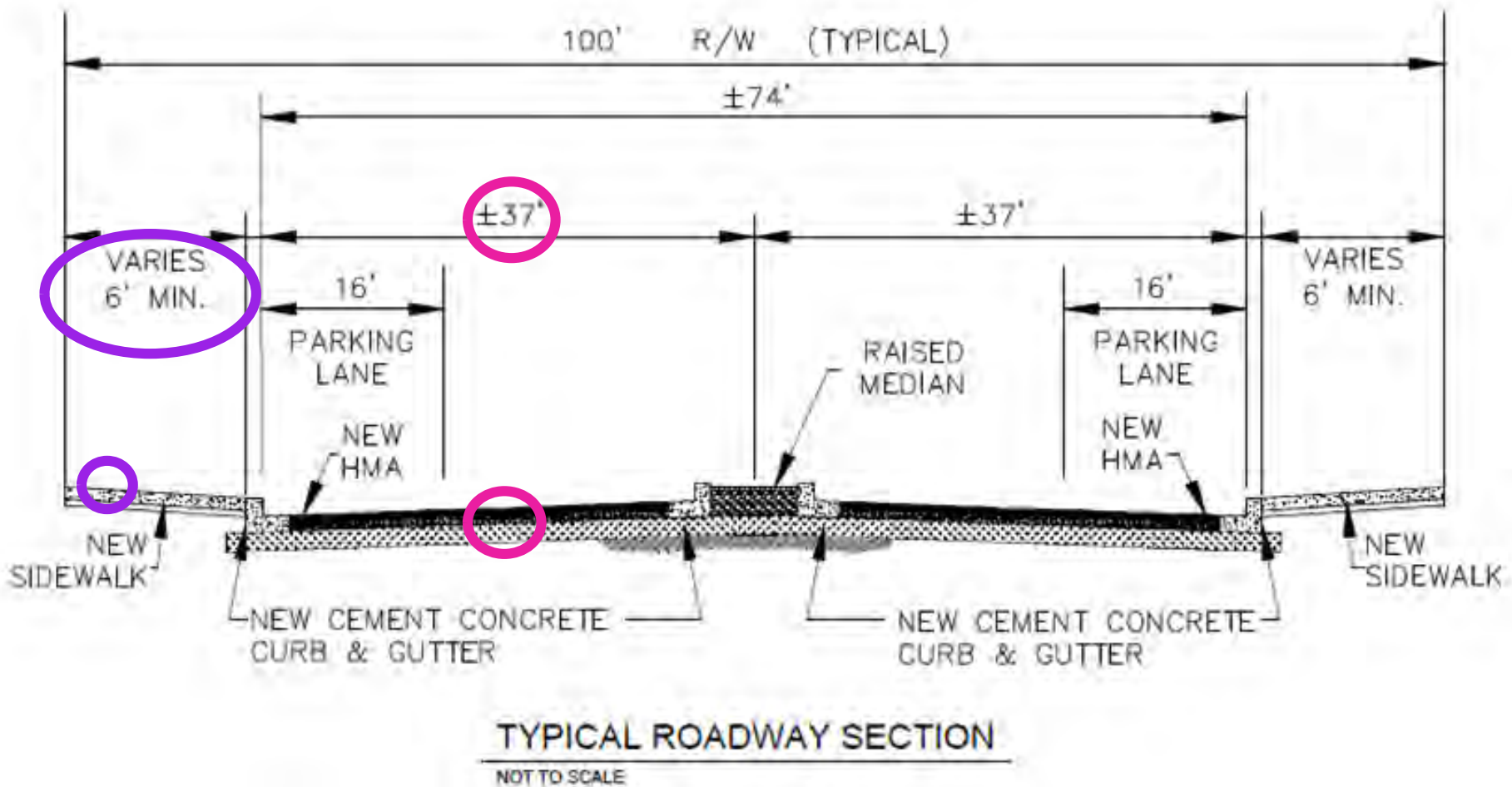



What is a Cross Section?

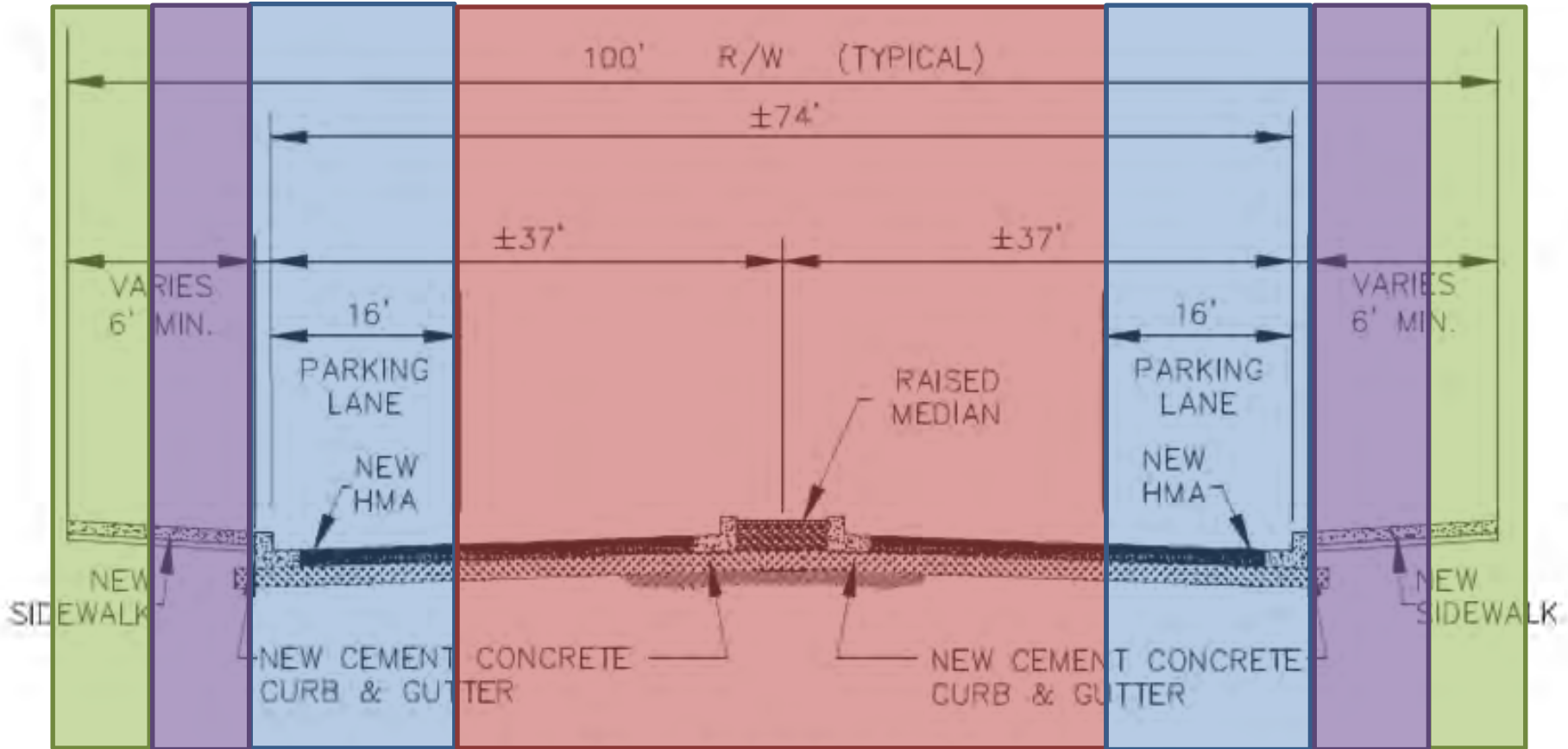

TYPICAL ROADWAY SECTION

NOT TO SCALE



Why is this Important?





Why are these productive streets?

N. Spokane, WA



Bedford, OH



Camas, WA

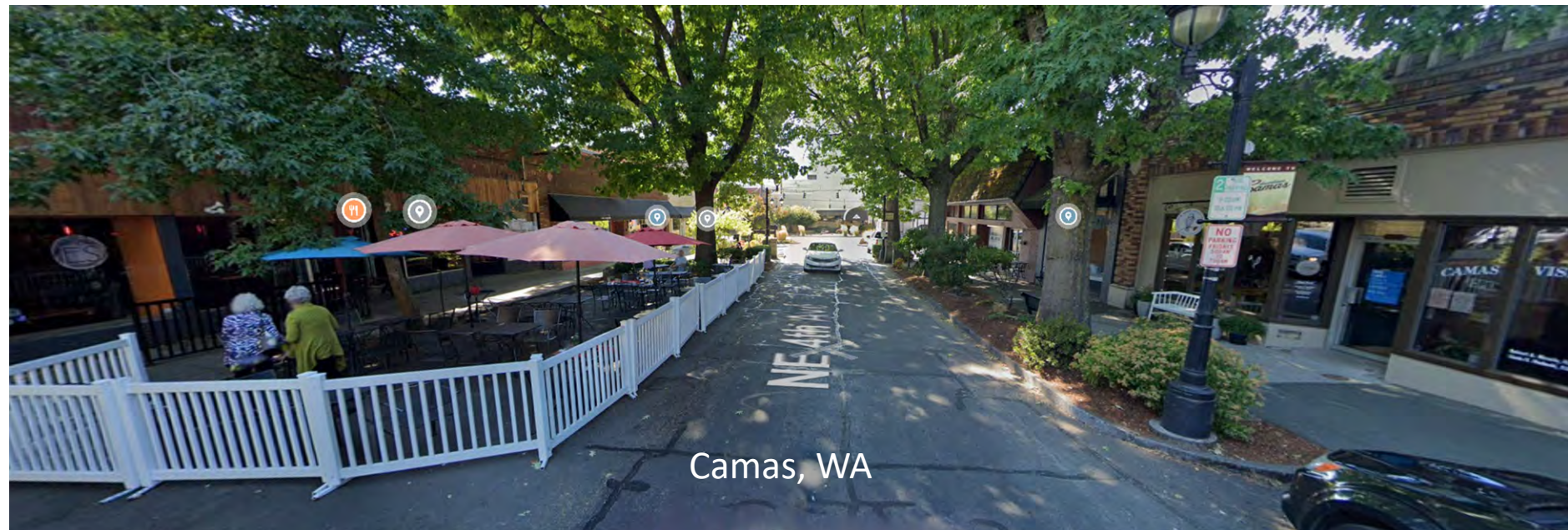



Why are these productive streets?



Carnation, WA



Lee's Summit, MO



Normal, IL



Basic Cross Section

- Frontage Zone – adjacent land use support
- Pedestrian Zone – movement of pedestrians, ADA
- Furnishing Zone – transitional, buffer, and services
- Parking Zone – freight business delivery, Bike/car access, TNCs
- Travelled Way – movement of vehicles





Tradeoffs

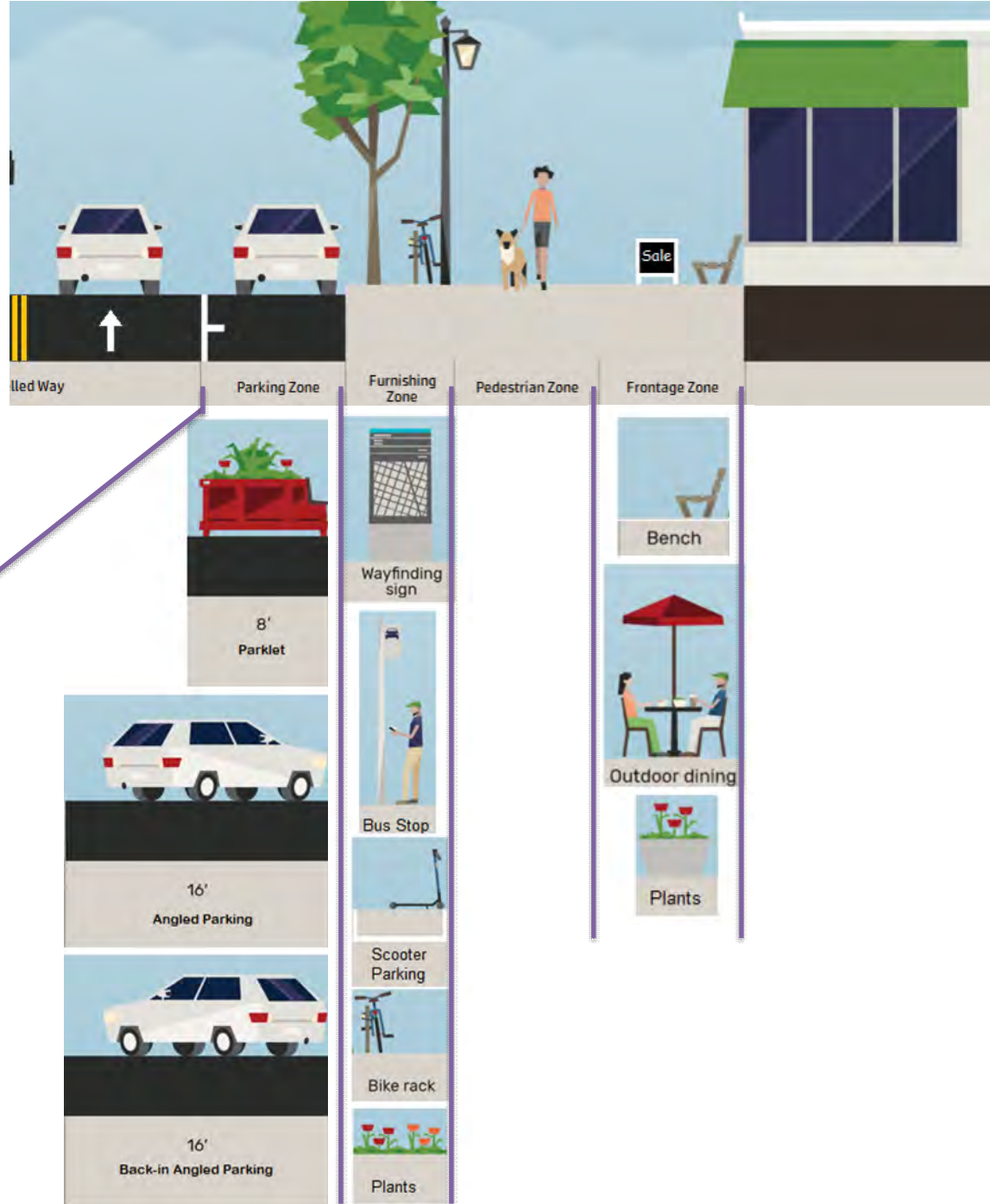



Cross Section Design

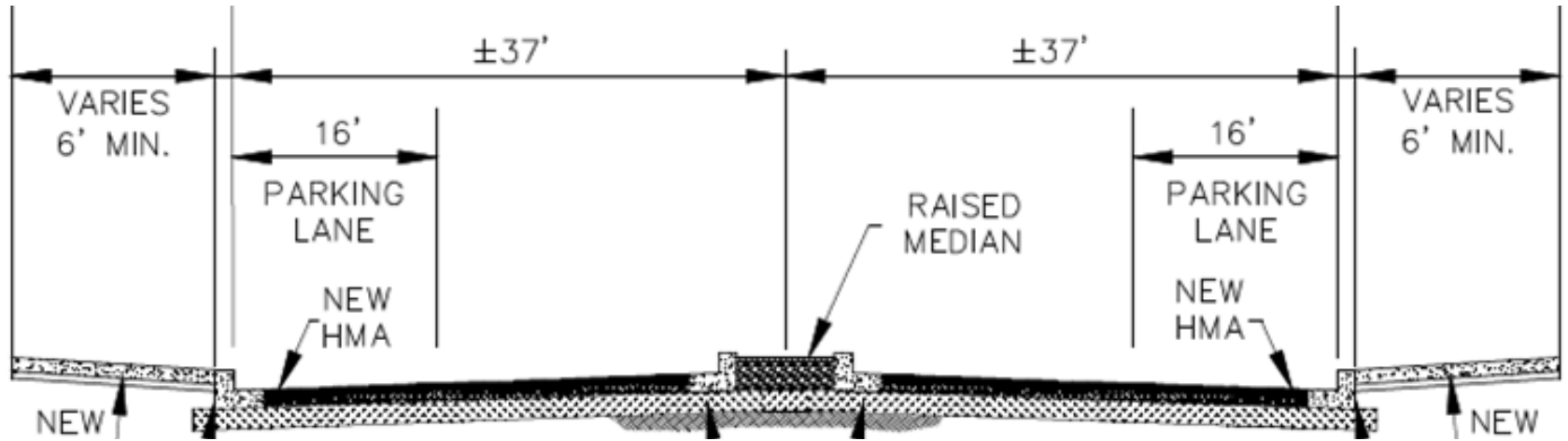



Cross Section Design

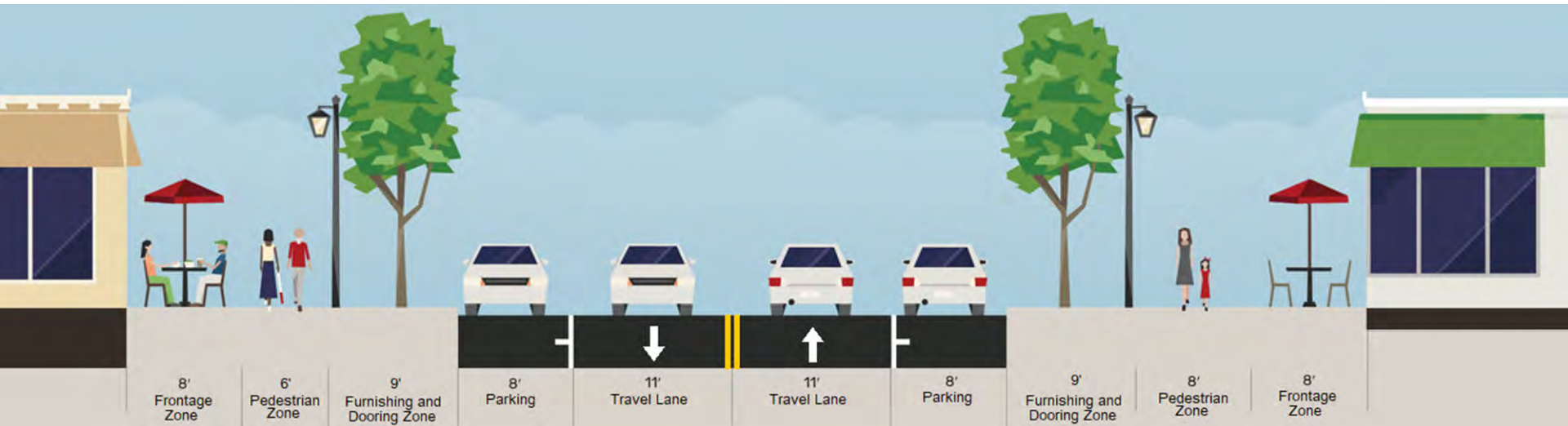



Cross Section Design

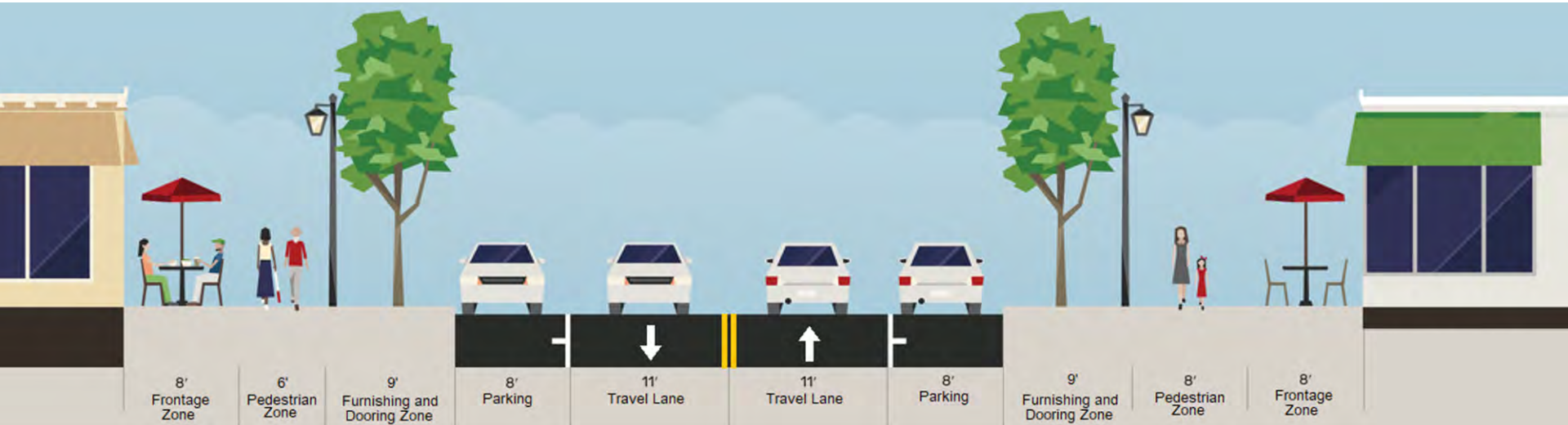
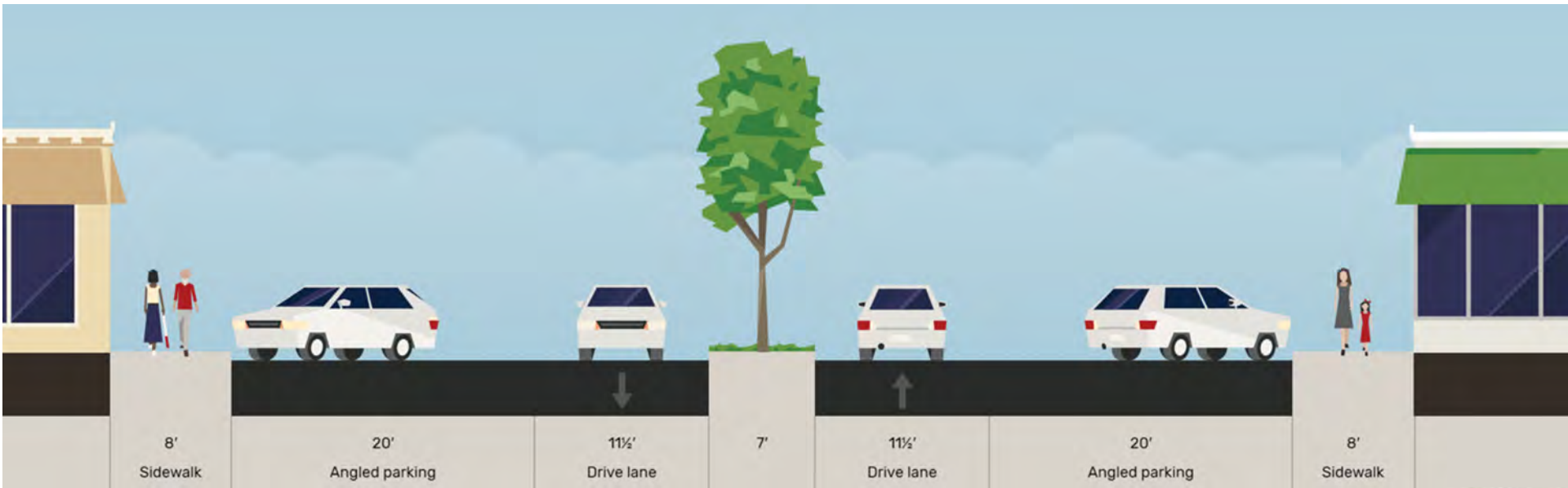



Cross Section Design

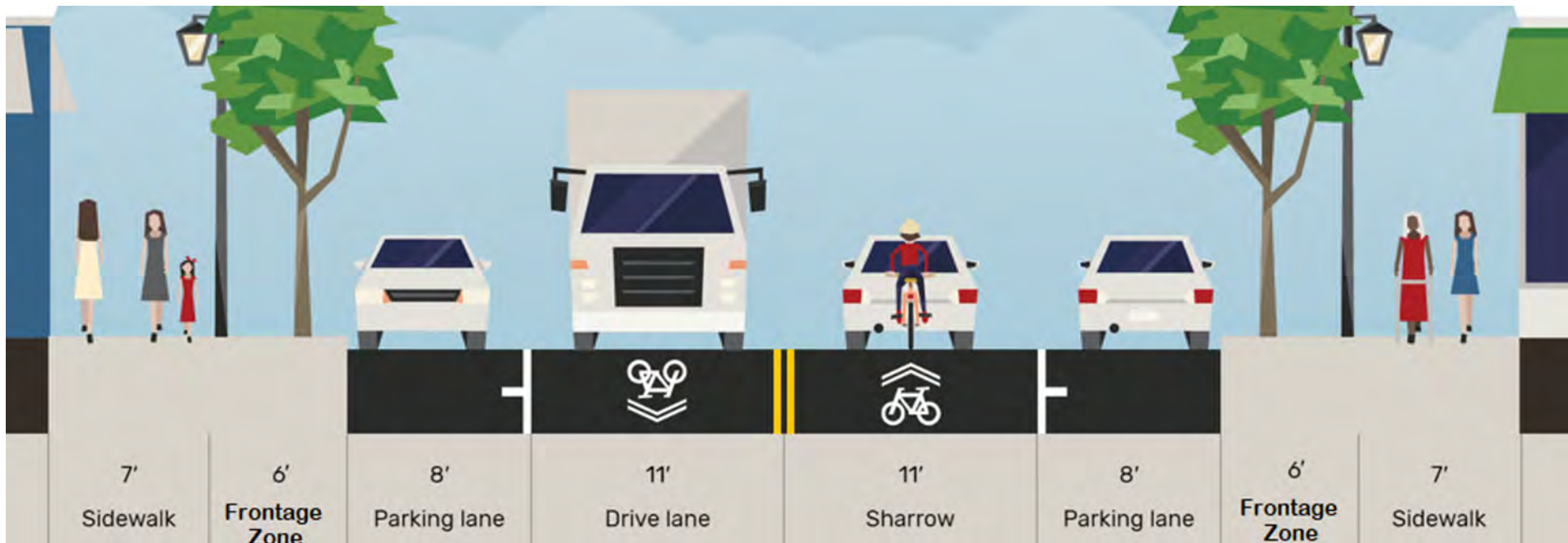
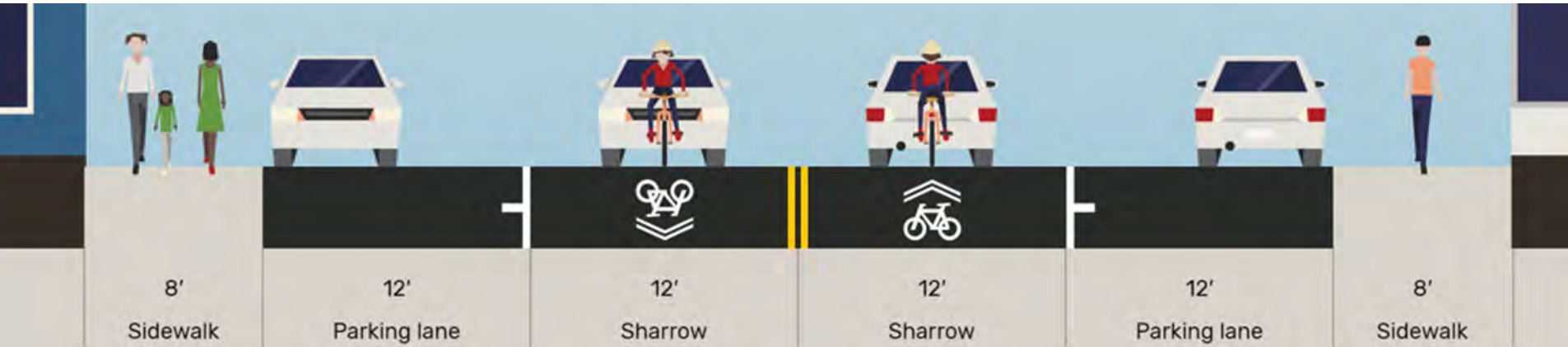



Cross Section Design

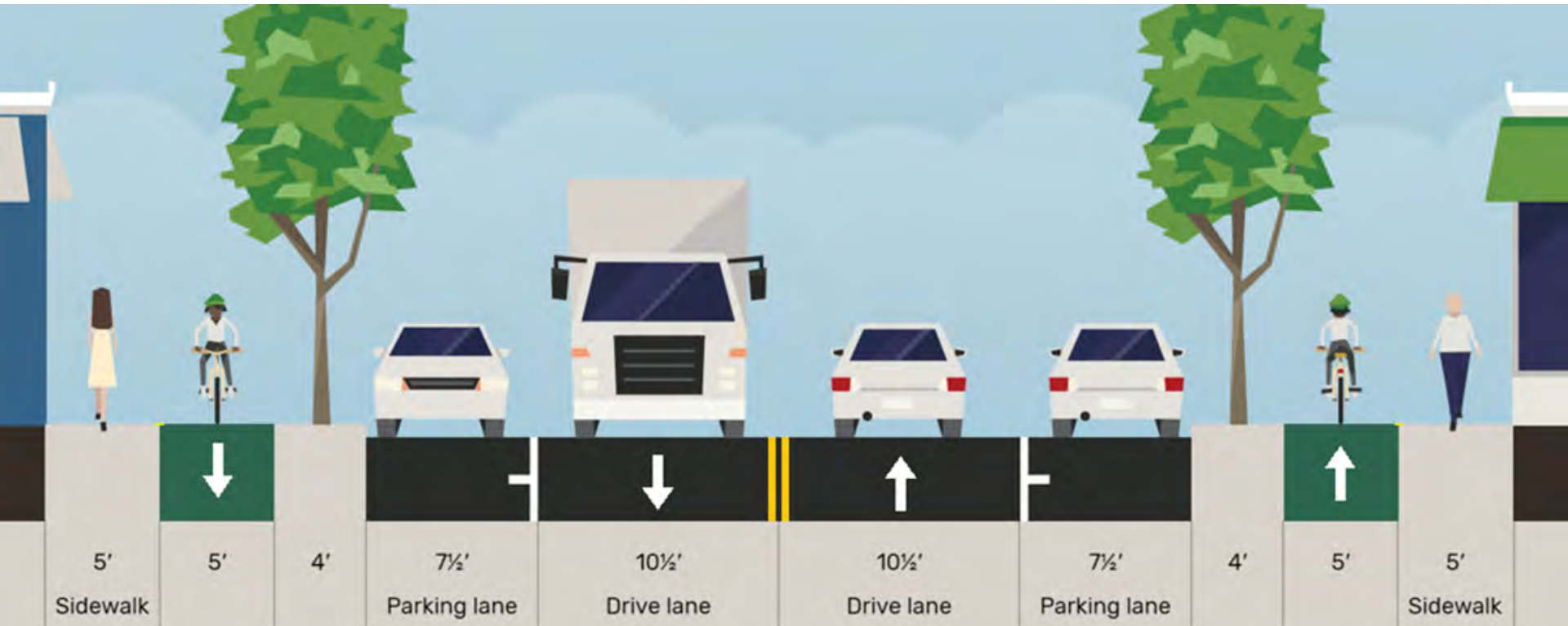
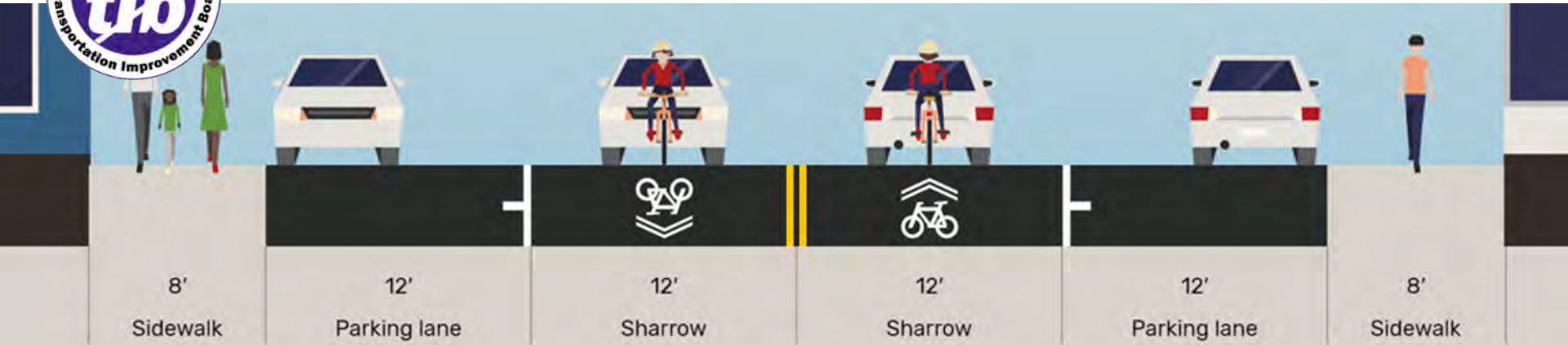



Cross Section Design





Questions?



“Investing in your community”

Chris Workman, PE
Engineering Manager
(360) 586-1153
chrisw@tib.wa.gov

Andrew Beagle, PE
Region Engineer
(360) 586-1151
andrewb@tib.wa.gov

www.tib.wa.gov
www.tib.wa.gov/tibdashboard